

Photosynthetically Active Radiation Sensor (PR10)

Features

- Incident short wave detector
- Silicon photovoltaic cell
- Accuracy $\pm 5\%$
- Cosine accuracy $\pm 3\%$
- High stability

Applications

- Scientific Research
- Agricultural Research

Description

The PR10 Series Photosynthetically Active Radiation Sensor measures incoming solar radiation in the frequency band suitable for green plants.

Plants use the 400-700 nm band in the visible spectrum for photosynthesis, and there is a direct relationship between the number of photons absorbed in this wavelength band and the number of carbon dioxide molecules involved in the photosynthetic chemical process.

As this relationship is independent of photon energy, photon flux density is the best measurement of incident radiation.

The response is a sloping straight line from 400 to 700 nm. The output is measured in micro-mols. (Units of irradiance)

A typical maximum intensity of the sensor is 2000 micro-mols per second, which is roughly equivalent to 1000 watts per metre squared of total solar radiation.



The specifications of the PR10 sensor are basically the same as for the solar radiation sensor, with the main difference being the band width and spectral position.

1000 micro-mols per second is equivalent to 10 Hertz output frequency.

Cosine correction is achieved by shaping a teflon diffuser and accurately housing this inside an opaque cylinder. A silicon photovoltaic cell is mounted inside the diffuser. This combination provides a standardised reading equivalent to radiation falling on a non-reflective, flat, surface.

For routine maintenance it is advisable that the top of the sensor be cleaned with a soft tissue to remove dust.

Envirodata Environmental Monitoring & Management

P.O. Box 395, WARWICK, Queensland, 4370, Australia

Phone: (07) 4661 4699

Int. Phone: + 61 7 4661 4699

e-mail: sales@envirodata.com.au

Fax: (07) 4661 2485

Int. Fax: +61 7 4661 2485

<http://www.envirodata.com.au>



Photosynthetically Active Radiation Sensor (PR10)

Specifications

Sensing Element:	Photovoltaic cell
Measurement Units:	Micro-mol
Spectrum Response:	A sloped response from 400 to 700 nanometres peaking at 700 nanometres
Linearity:	Max. deviation of 1% up to 700 nanometres
Cosine Correction:	Cosine corrected to 3% up to 80° angle of incidence
Azimuth Error:	Less than 2% over 360° at 45° elevation
Stability:	Less than 2% change over a 1 year period
Temperature Stability:	max. 0.15%/°C
Calibration:	Calibrated against Envirodata's standard PAR sensor
Reliability:	Capable of operating for a period of five (5) years before overhaul.
Operating Conditions:	Temperature: -20°C to +50°C Humidity: 0% to 100%
Sensor Mounting:	Unobstructed sky at elevations > 5°
Supply Voltage:	5.5 to 7 Volts DC
Current Drain:	< 0.5 mA
Output:	+5 Volt Pulse

Configuration

Model	PR10
Output (micro-mol/m ² /pulse)	100
Resolution (micro-mol/m ²)	100
Cable Type	3-core shielded
Cable Length	1.5m

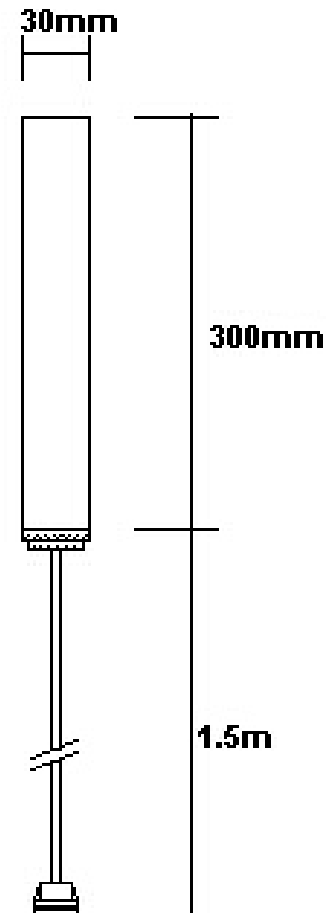

Envirodata Environmental Monitoring & Management

P.O. Box 395, WARWICK, Queensland, 4370, Australia

Phone: (07) 4661 4699

Int. Phone: + 61 7 4661 4699

e-mail: sales@envirodata.com.au

Fax: (07) 4661 2485

Int. Fax: +61 7 4661 2485

<http://www.envirodata.com.au>