

Solar Radiation Sensor *Pyranometer* (SR10)

Features

- Incident short wave detector
- Silicon photovoltaic cell
- Accuracy $\pm 5\%$
- Cosine accuracy $\pm 3\%$
- High stability

Applications

- Solar Radiation Intensity
- Meteorological
- Agricultural
- Irrigation management
- Bush fire management

Description

The SR10 Series Solar Radiation Sensor is a general purpose global incoming solar radiation sensor with cosine correction. It has been designed for recording hours of sunshine as well as total incident solar energy. Cosine correction is achieved by shaping a teflon diffuser and accurately housing this inside an opaque cylinder. A silicon photovoltaic cell is mounted inside the diffuser. This combination provides a standardised reading equivalent to radiation falling on a non-reflective, flat, surface.



For clear unobstructed daylight conditions, the SR10 series compares favourably with first class thermopile-type pyranometers at a fraction of the cost. The spectral response of the Envirodata pyranometer does not cover the full range of the solar spectrum, but the error introduced is less than $\pm 5\%$ under most conditions of natural daylight. SR10 Series readings should not be taken as absolute when recording under vegetation or artificial lights.

For routine maintenance it is advisable that the top of the sensor be cleaned with a soft tissue to remove dust.

Envirodata Environmental Monitoring & Management

P.O. Box 395, WARWICK, Queensland, 4370, Australia

Phone: (07) 4661 4699

Int. Phone: + 61 7 4661 4699

e-mail: sales@envirodata.com.au

Fax: (07) 4661 2485

Int. Fax: +61 7 4661 2485

<http://www.envirodata.com.au>



Solar Radiation Sensor (SR10 Series)

Specifications

Sensing Element:	Photovoltaic cell
Measurement Units:	watts/m ² (intensity) Joules/m ² (energy)
Spectrum Response:	<-3dB from 400 to 1000 nanometres peaking at 900 nanometres
Linearity:	Max. deviation of 1% up to 2000 watts/m ²
Cosine Correction:	Cosine corrected to 3% up to 80° angle of incidence
Azimuth Error:	Less than 2% over 360° at 45° elevation
Stability:	Less than 2% change over a 1 year period
Temperature Stability:	max. 0.15%/°C
Calibration:	Calibrated against a standard thermo-pile pyranometer.
Reliability:	Capable of operating for a period of five (5) years before overhaul.
Operating Conditions:	Temperature: -20°C to +50°C Humidity: 0% to 100%
Sensor Mounting:	Unobstructed sky at elevations > 5°
Supply Voltage:	5.5 to 7 Volts DC
Current Drain:	< 0.1 mA
Output:	+5 Volt Pulse

Configurations

Model	SR10	SR11
Output (Joules/pulse)	200	5
Resolution (Joules/m ²)	200	5
Cable Type	3-core shielded	3-core shielded
Cable Length	1.5m	1.5m

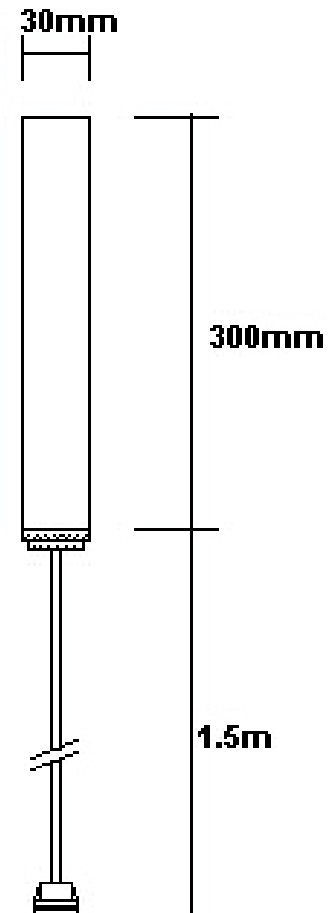

Ordering Information

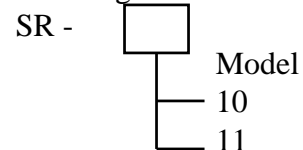

Envirodata Environmental Monitoring & Management

P.O. Box 395, WARWICK, Queensland, 4370, Australia

Phone: (07) 4661 4699

Int. Phone: + 61 7 4661 4699

e-mail: sales@envirodata.com.au

Fax: (07) 4661 2485

Int. Fax: +61 7 4661 2485

<http://www.envirodata.com.au>